

OPERATING VOLTAGE: 115 VAC  
 OPERATING FREQUENCY: 47 - 447 Hz  
 CURRENT: 7 AMP MAX.

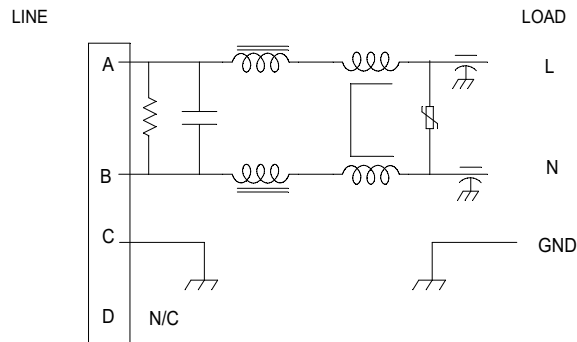
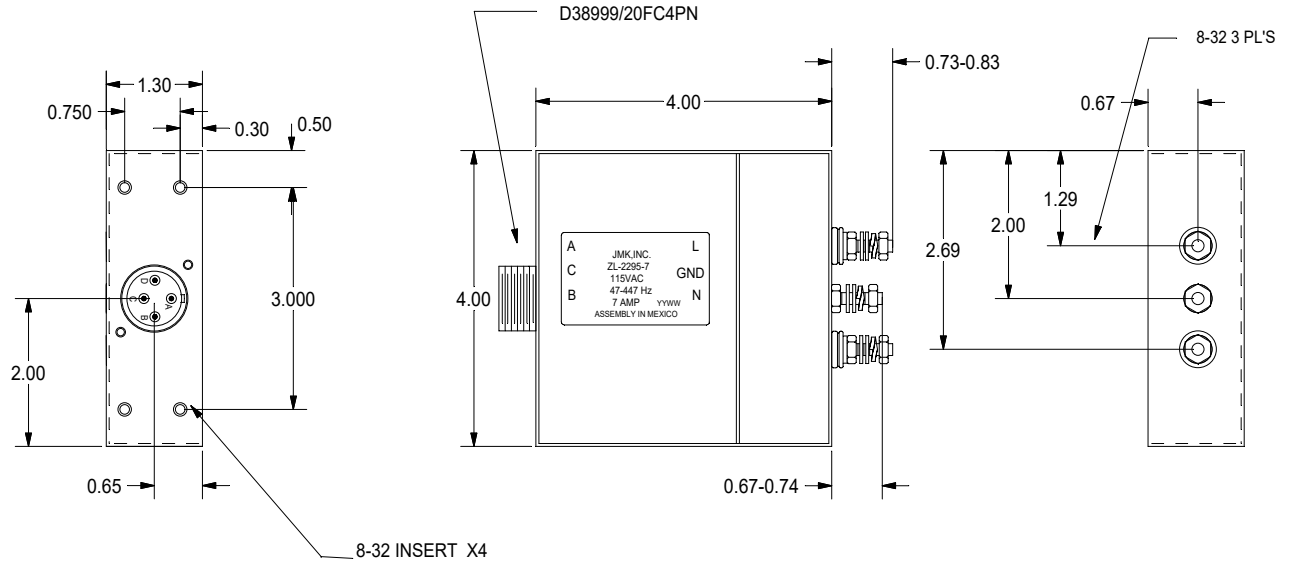
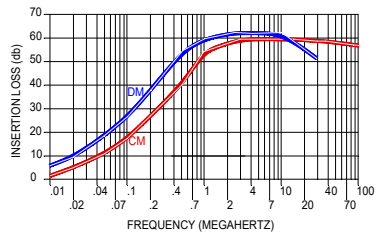

SCALE	APPROVED BY
DATE 1/14/16	DRWN BY JFM
	REV DATE 5/18/16
<b>SPECIFICATION</b>	
REVISION <b>B</b>	
TOLERANCE .XX = .02 .XXX = .005	DRAWING NO. <b>ZL-2295-7</b>
DIM: INCHES (mm)	